

POLE SHAFT SPECIFICATIONS				
NO.				
1.	SHAFTS ARE ONE SECTION DESIGN FABRICATED FROM A WELDABLE GRADE CARBON STEEL STRUCTURAL TUBING (ASTM A500 GR. B) WITH A UNIFORM WALL THICKNESS. MATERIAL SHALL CONFORM TO ASTM A-500 GRADE B WITH A MINIMUM YIELD STRENGTH OF 46,000 P.S.I.			
2.	BASE PLATES ARE CONSTRUCTED OF A STRUCTURAL QUALITY HOT ROLLED CARBON STEEL PLATE (ASTM A36) WITH A GUARANTEED MINIMUM YIELD STRENGTH OF 36,000 P.S.I.			
3.	ANCHOR BOLTS ARE "L" FORMED BARS HAVING A MINIMUM YIELD STRENGTH OF 55,000 P.S.I., FABRICATED FROM ASTM F1554 GR. 55, THE BOLTS ARE FULLY GALVANIZED PER ASTM A153 SPECIFICATIONS. FURNISHED COMPLETE WITH 2 HEX NUTS AND 2 FLAT WASHERS.			
4.	POLES SHALL HAVE A POLYESTER POWDER COAT FINISH IN A STANDARD COLOR.			
POLE DIMENSIONS				
POLE HGT. (FT.)	TOP DIA. (IN.)	BOTTOM DIA. (IN.)	GAGE	MTG. HGT. (FT.)
30'	5.00	5.00	7 GAGE	30'
BASE PLATE DIMENSIONS				
BOLT CIRCLE (IN.)	BASE PLATE DIM. (IN.)	BOLT HOLE (IN.)	PLATE THK. (IN.)	
9.50-10.50	10.00 SQ	1.25	1.00	
ANCHOR BOLT DIMENSIONS				
ANCHOR BOLT DIA. (IN.)		ANCHOR BOLT LENGTH (IN.)		
1.00		40.00		
ALLOWABLE WIND LOADING (SQ. FT.)				
WIND*	80 MPH	90 MPH	100 MPH	120 MPH
EPA	7.9	6.6	4.8	2.7

*WITH 1.3 GUST FACTOR

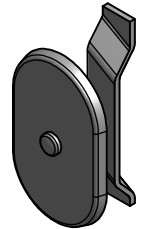

3.00 X 5.00 HAND HOLE COVER

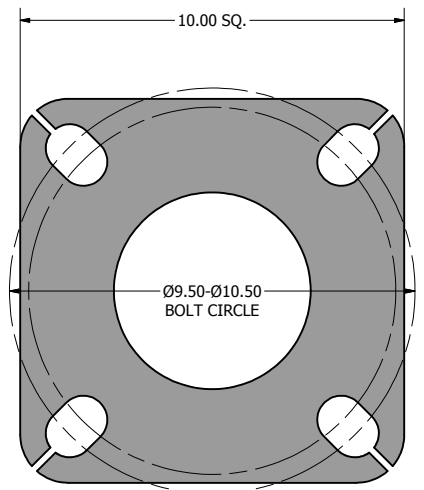

10.00 X 10.00 X 1.00 THK. BASE PLATE

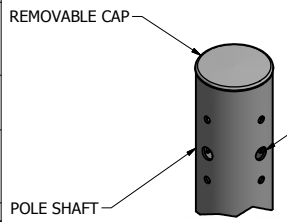

DRILLED MOUNT OPTIONS

REMOVABLE CAP
POLE SHAFT

DRILLED PER FIXTURE REQUIREMENTS:
D1- DRILLED FOR 1 FIXTURE
D2- DRILLED FOR 2 FIXTURES AT 90° OR 180°
D3- DRILLED FOR 3 FIXTURES AT 90° OR 120°
D4- DRILLED FOR 4 FIXTURES

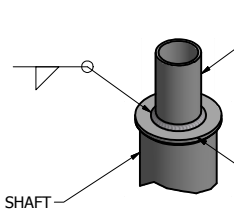

TENON MOUNT OPTIONS

TENON MOUNT OPTIONS:
T2- Ø2.38 X 4.00 LG
T3- Ø3.00 X 5.00 LG
T4- Ø4.00 X 6.00 LG

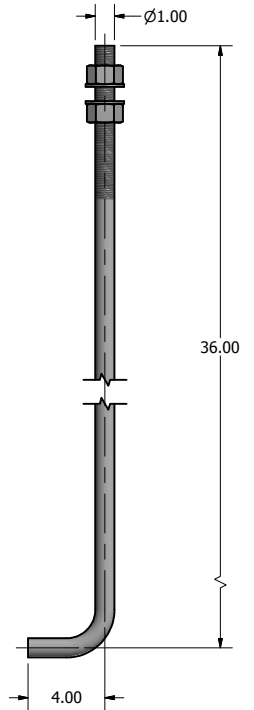

Ø1.00 X 40.00 ANCHOR BOLT

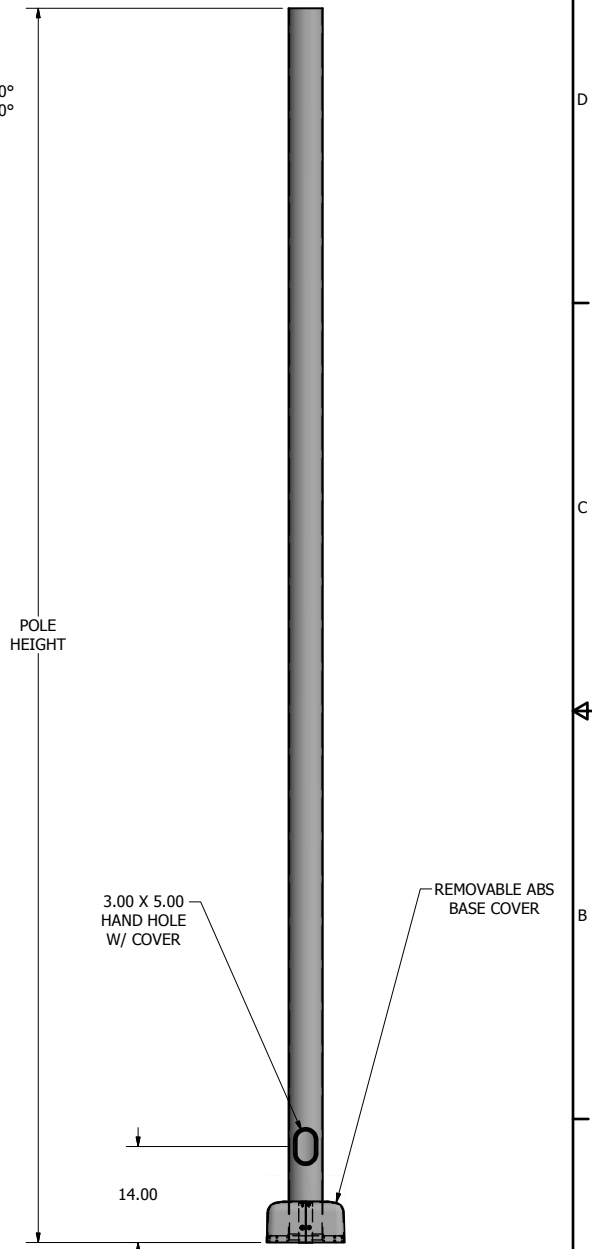

POLE DETAIL

lyte poles
a DWM company

P.O. Box 340
Eastpointe, MI 48021
P: (586) 771-4610 | F: (586) 771-5527
www.lytepoles.com

DRAWN: M. HARVALA	2/13/2015
CHECKED:	
REVISION:	DATE:
APPROVED:	
QUOTE:	
S.O.#	
REF:	SCALE: NONE

SOME GEOGRAPHICAL AREAS HAVE SPECIAL WIND CONDITIONS THAT CAN CREATE WIND INDUCED VIBRATIONS CAUSING A FATIGUE PROBLEM. NO METHOD HAS YET BEEN FOUND FOR PREDICTING DESTRUCTIVE LIGHTING POLE VIBRATION. THESE CONDITIONS ARE UNIQUE AND CANNOT BE GUARANTEED AGAINST, AND ARE THE RESPONSIBILITY OF A LOCAL SITE ENGINEER.	
TITLE:	
CATALOG:	
DWG NO: 401-5007-30	SIZE C
SHEET 1 OF 1	

